

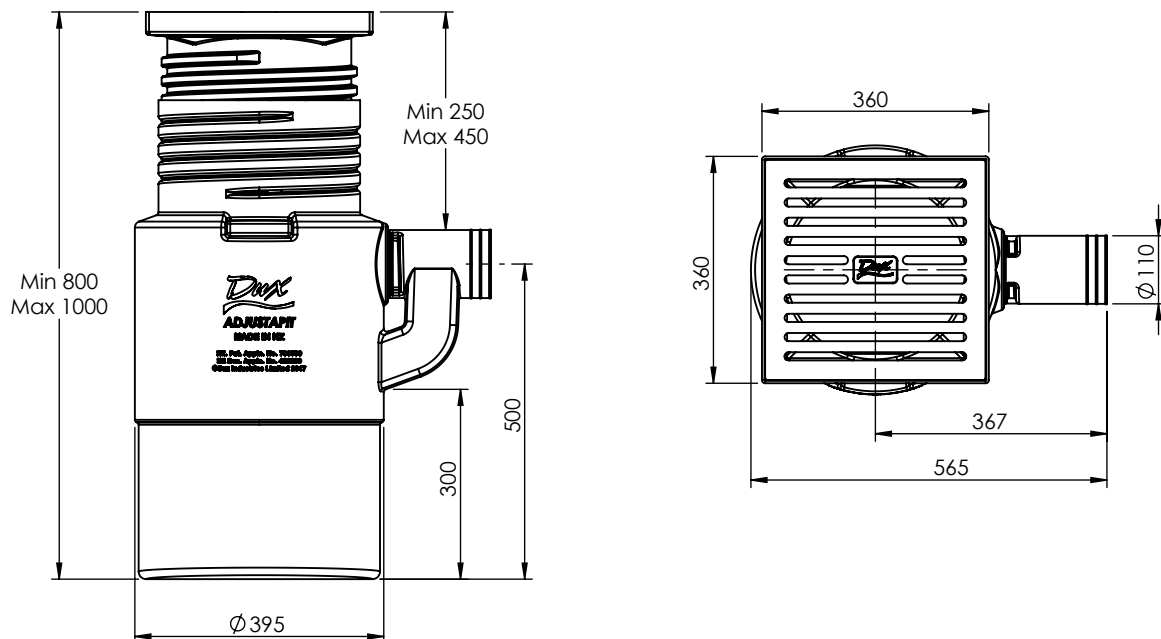

**FEATURES**

- Square 350mm cast iron grate with 5 tonne load rating
- Square riser with 200mm of height adjustment
- Integrated external trap with 100mm outlet
- Removable outlet access plug for ease of cleaning
- Building code compliant Type-one surface water sump
- Made from UV stabilized Low Density Polyethylene
- All plastic components made in NZ
- 20 year warranty on pit & grate

**DIMENSIONS  
 (mm)**



Date: 24/08/2018 Version: 1

**TECHNICAL SPECIFICATION**

All Dux AdjustaPits<sup>™</sup> are made from a high grade Linear Low Density Polyethylene (LLDPE) which has high environmental stress crack resistance (ESCR), high chemical resistance and has an exceptional balance of stiffness and toughness making it ideal for its application.

The material is also UV stabilized to meet Australasian conditions and exceeds the UV requirements of AS/NZS4766:2006.

Dux AdjustaPit<sup>™</sup> should not be used for hot water applications above 70°C.

Refer to Building Code, Acceptable Solutions E1/AS1 for full details on the catchment area suitable for type one sumps.

Further details of the Dux AdjustaPit<sup>™</sup> range of silt pits is available for download at [www.dux.co.nz](http://www.dux.co.nz) Dux Industries reserves the right to alter or amend the specifications of the Dux AdjustaPit<sup>™</sup> range without prior notice. Dux AdjustaPit<sup>™</sup> is a registered trade mark of Dux Industries Ltd.